

# Li-Polymer Battery Technology Specification

**Reference** BAT531

**Part name** Li-Polymer Battery

**Model No** LIPO 043040 420mAh 3.7V

## 1. SCOPE

This document describes the performance characteristics and testing methods for polymer Lithium-ion batteries

## 2. SPECIFICATION

No.	Item	Characteristics	Remarks
1	Nominal Capacity	Minimum: 399mAh Typical: 420mAh	Standard discharge (0.2C <sub>5</sub> A) after Standard charge
2	Nominal Voltage	3.7V	—
3	Charging Cut-off Voltage	4.2V	—
4	Discharge Cut-off Voltage	3.0V	—
5	Standard Charge	Constant Current 0.5C <sub>5</sub> A Constant Voltage 4.2V 0.01 C <sub>5</sub> A cut-off	Charge Time : Approx 4.0h
6	Maximum Constant Charging Current	420mA (1.0C)	—
7	Standard Discharge	Discharge at 0.2 C <sub>5</sub> A to 3.0V	—
8	Maximum Continuous Discharging Current	630mA (1.5C)	—
9	Operating Temperature	Charge 0~45°C Discharge -20~60°C	—
10	Storage Temperature	-20~45°C for 1Month -10~35°C for 6Months	—
11	Storage Voltage	3.7-3.85V	—
12	Environmental request	RoHS	If the materials of the product and packaging accord with RoHS standard, there will be a RoHS Id on the box.

## 3. Dimensions

Please refer the drawing in appendix.

## 4. Appearance

No scratches, dirt, defect, leakage of electrolyte or gassing should be observed as a new product.

## 5. Standard Testing Environment

Temperature :  $25\pm 2^{\circ}\text{C}$

Relative humidity :  $65\pm 20\%$  ( unless specially requested )

## 6. Characteristics

### 6.1 Electrochemical performance characteristics

No.	Item	Testing Method	Requirements
1	Fully Charged State	CCCV or Constant current charge to 4.2V @0.5C follow by a constant voltage holding at 4.2V until current drops below $4\pm 2\text{mA}$ .	—
2	Rated Capacity	0.5c CCCV 0.01c at 4.2V (per 6.1.1) at room temp. ( $20\pm 5^{\circ}\text{C}$ ), rest for 1-2 hrs then discharge at a constant current of 0.2C to 3.0V, testing will be terminated by either 5 cycles or any one discharge time exceeds 5 hrs	$\geq 399\text{mAh}$
3	Cycle Life @ $25^{\circ}\text{C}$	Discharge to 3.0V @0.2C, then 0.5c CCCV 0.01C charge to 4.2V, rest for 10 min. discharge @ 0.2C to 3.0V and rest for 10 min. Continue the charge/discharge cycles until discharge capacity lower than 70% of rated capacity.	Cycle life $\geq 500$
4	Internal Impedance	Internal impedance is measured on a 50% charged battery at 1KHz AC at ambient temperature ( $20\pm 2$ ) $^{\circ}\text{C}$	—
5	Capacity Retention	Fully charge cells per 6.1.1, store them at ( $20\pm 2$ ) $^{\circ}\text{C}$ for 28 days, then discharge the cells to 3.0V at 0.2C.	Discharge Capacity $\geq 336\text{mAh}$
6	High Temperature Characteristics	Fully charge cells per 6.1.1, store them at ( $55\pm 2$ ) $^{\circ}\text{C}$ for 2 hours, then discharge the cells to 3.0V at 0.2C.	Discharge Capacity $\geq 336\text{mAh}$
7	Low Temperature Characteristics	Fully charge cells per 6.1.1, store them at ( $-10\pm 2$ ) $^{\circ}\text{C}$ for 16~24 hours, then discharge the cells to 3.0V at 0.2C.	Discharge Capacity $\geq 252\text{mAh}$
8	Cell Voltage during Transportation	Check open circuit voltage (OCV) of cells prior to the delivery to customers	$\geq 3.75\text{V}$

### 6.2 Safety characteristic

No.	Item	Test Method	Requirements
1	Over charge	Discharge cells to 2.4V at 0.2C, then charge to 4.45V at 3C and rest for 8 hours.	No fire No explosion No leakage
	Overdischarge	Fully charge cells per 6.1.1, then discharge the battery to 3.0V with 0.2CmA at room temperature, connect with external load of $30\Omega$ for 24 hours.	No fire No explosion No leakage

3	Hot Oven Test	Put a fully charged battery in a forced air oven and raise the temperature at $5\pm 2^{\circ}\text{C}/\text{min}$ . to $130\pm 2^{\circ}\text{C}$ Rest for 10 minutes.	No fire No explosion No leakage
---	---------------	--	---------------------------------------

### 6.3 Reliability

No	Item	Test Method	Requirements
1	High Temperature Test	Fully charged per 6.1.1, then rest at $60\pm 2^{\circ}\text{C}$ for 2 hours.	Electrochemical performance, visual test not changed
2	Low Temperature Test	Fully charge cells per 6.1.1, rest at $-20\pm 2^{\circ}\text{C}$ for 2 hours. Then the cells are placed at room temperature for 3 hours.	No appreciable alternation electrochemically and visually
3	Humidity Test	Fully charge cells per 6.1.1, rest at $40\pm 2^{\circ}\text{C}$ with 90%~95RH% for 48 hours. Then the cells are placed at room temperature to "dry out" for 2 hours.	No appreciable alternation electrochemically and visually
4	Vibration Test	After standard charged, fixed the cell to vibration table and subjected to vibration cycling that the frequency is to be varied at the rate of 1Hz per minute between 10Hz and 55Hz, the excursion of the vibration is 1.6mm. The cell shall be vibrated for 30 minutes per axis of XYZ axes.	No fire No explosion No leakage
5	Drop Test	The cell is to be dropped from a height of 1 meter twice onto concrete ground.	No fire No explosion No leakage
6	Collisions	After the vibration test, according to X.Y.Z each battery average three vertical pulse peak acceleration, the setting for the $100\text{m/s}^2$ , every minute, 40 ~ 80 collision frequency, pulse duration 16ms collision frequency $\pm 10$ thousand.	No fire No explosion No leakage
7	Crush (Fresh, Fully charged)	Crush between two flat plates. Applied force is about 13kN(1.72Mpa) for 30min.	No fire No explosion No leakage
8	Short Circuit	This test will be placed the battery electric dipole in the fume hood, short-circuit the anode (total resistance is not more than $50\text{m}\Omega$ lines), monitor temperature changes, when the battery is low temperature dropped to about 10 degrees than peak, the end of experiment.	No explosion, No fire The temperature of the surface of the Cells $\leq 150^{\circ}\text{C}$

9	Impact(Fresh, Fully charged)	A 56mm diameter bar is inlaid into the bottom of a 10kg weight. And the weight is to be dropped from a height of 1m onto a sample battery and then the bar will be across the center of the sample.	No fire No explosion No leakage
10	Thermal shock(Fresh, Fully charged)	Batteries in hot box Temperature in $5^{\circ}\text{C}\pm 2^{\circ}\text{C}/\text{min}$ , rising to $50^{\circ}\text{C}\pm 2^{\circ}\text{C}$ keep 30min	No fire No explosion No leakage
11	Constant damp performance	After Standard charge of battery, Will a battery into $40^{\circ}\text{C}\pm 2^{\circ}\text{C}$ , Relative humidity 90%~95% At constant temperature and humidity box after 48h Battery will in environmental temperature $20\pm 5^{\circ}\text{C}$ Aside 2h, 0.2C <sub>5</sub> A to terminate discharge current voltage,	No obvious deformation, hands rust, smoke, explosion, discharge time $\geq 36$ min

## 7. Warranty

Warranty period for this product is 6 months starting from the date when the products left the door of manufacturer.

## 8. Liability

The user has to operate the products according to the instructions printed on the battery label or follow the advices described in this "Product Specification for Lithium Ion Batteries published

- 5 -

## 9. Battery Packing Label

The following warnings should be indicated on the battery pack labels.

- Use a specified charger.
- Do not throw the battery into fire, or heat.
- Do not short-circuit the battery terminals.
- Do not disassemble the battery.
- 

## 10. Warnings and Cautions in Handling the Lithium-ion Battery

To prevent potential leaking, overheating or explosion of batteries please be advised to take following precautions:

### WARNINGS!

- Do not immerse the battery in water or seawater, and keep the battery in a cool dry environment during stands by period.
- Do not use or leave the battery near a heat source such as fire or heater.

- When recharging, use the battery charger specifically for that purpose.
- Do not reverse the position (+) and negative (-) terminals.
- Do not connect the battery to an electrical outlet.
- Do not dispose the battery in fire or heat.
- Do not short-circuit the battery by directly connecting the positive (+) and negative (-) terminal with metal objects such as wire.
- Do not transport or store the battery together with metal objects such as necklaces, hairpins etc.
- Do not strike or throw the battery against hard surface.
- Do not directly solder the battery and pierce the battery with a nail or other sharp object.
- Outer metal conduct can not contact the aluminum layer in AL laminate film, especially with electrification ,which will be “black spot ”and swelling easily.
- Do not use sharp things to hit the battery.

#### CAUTIONS!

- Do not use or leave the battery at very high temperature (for example, at strong direct sunlight or in a vehicle in extremely hot weather). Otherwise, it can overheat or fire or its performance will be degenerate and its service life will be shortened.
- Do not use it in a location where static electricity is rich, otherwise, the safety devices may be damaged, causing a harmful situation.
- In case the electrolyte get into the eyes due to the leakage of battery, do not rub the eyes! Rinse the eyes with clean running water, and seek medical attention immediately. Otherwise, it may injure eyes or cause a loss of sight. - 6 -
- If the battery gives off an odor, generates heat, becomes discolored or deformed, or in any way appear abnormal during use, recharging or storage, immediately remove it from the device or battery charger and place it in a contained vessel such as a metal box.
- In case the battery terminals are contaminated, clean the terminals with a dry cloth before use. Otherwise power failure or charge failure may occur due to the poor connection between the battery and the electronic circuitry of the instrument.
- Be aware discarded batteries may cause fire, tape the battery terminals to insulate them before disposal.

## 11. Protection board principle diagram

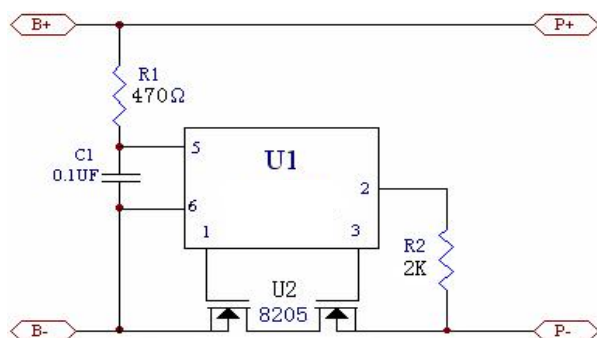

## 12. Protection board component

Item 序号	Part Name 元件	Description 规格	QTY 数量
1	U1	DW01	1pcs
2	U2	8205	1pcs
3	R1	SMD 470 Ω ±5%	1pcs
4	R2	SMD 2K Ω ±5%	1pcs <sup>-7-</sup>
5	C1	SMD 0.1 μ F ±20%	1pcs

## 13. Protection board electrical properties

No	Items	Criteria	Unit
1	Overcharge Detection Voltage	4.3±0.05	V
2	Overdischarge Detection Voltage	2.4±0.1	V
3	Overcurrent Detection current	2-5	A
4	Supply current	≤7.0	uA

## 14. Dimensions

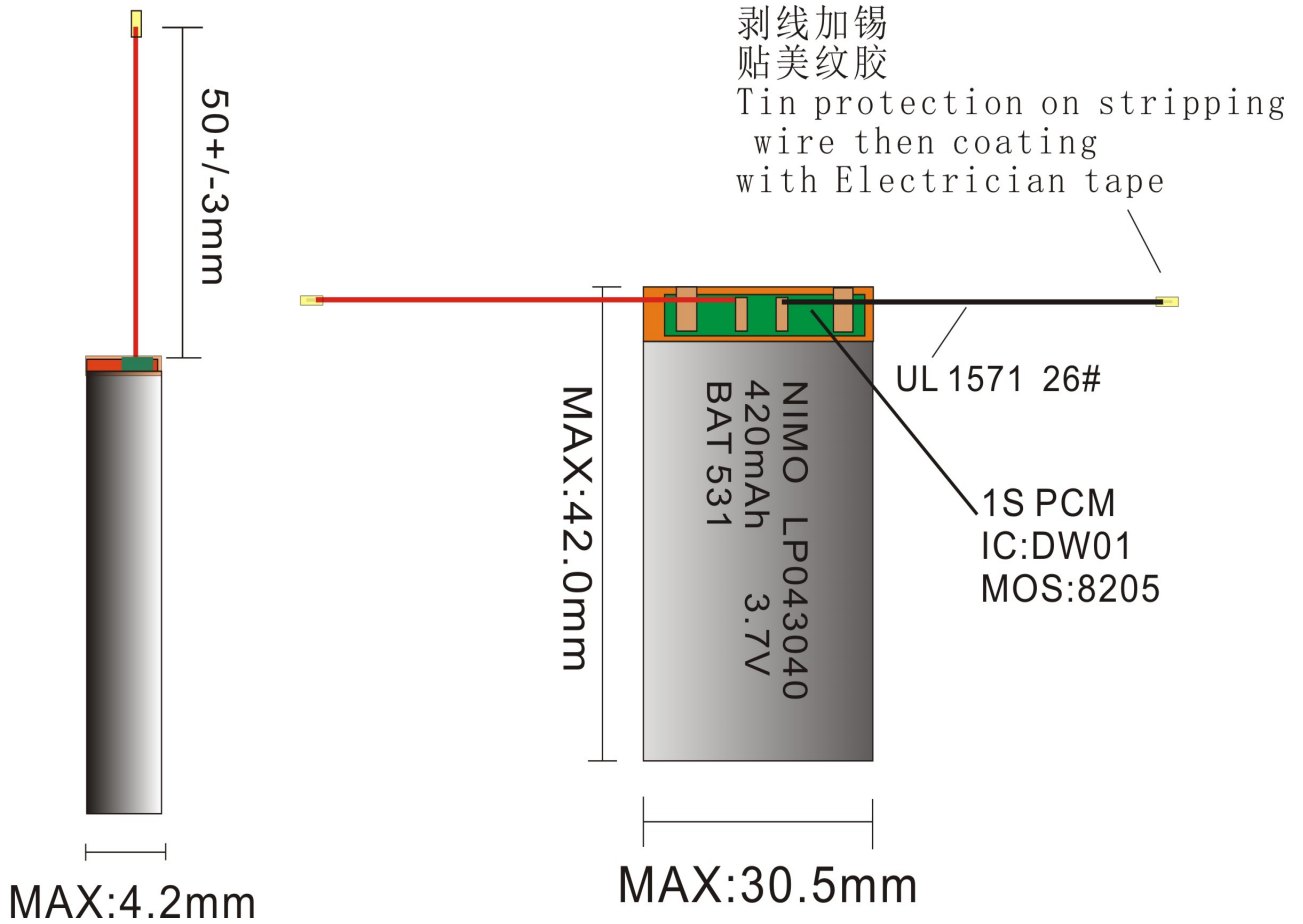

.....END.....